

Designer: Eric Bergen, 14 years old  
Designed: 29-9-2011  
Diagrammed: 28-1-2012

# Swimming Dino

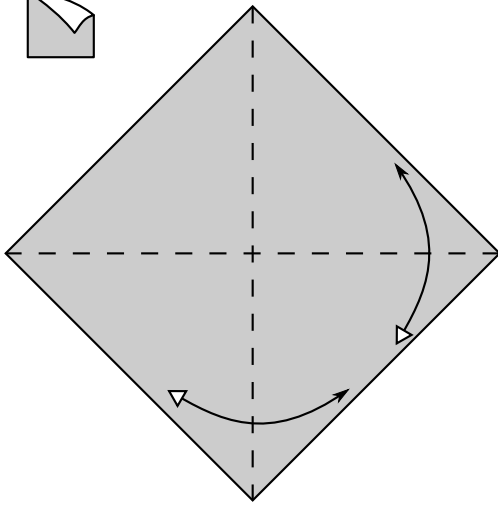

1. Color up. Fold and unfold.

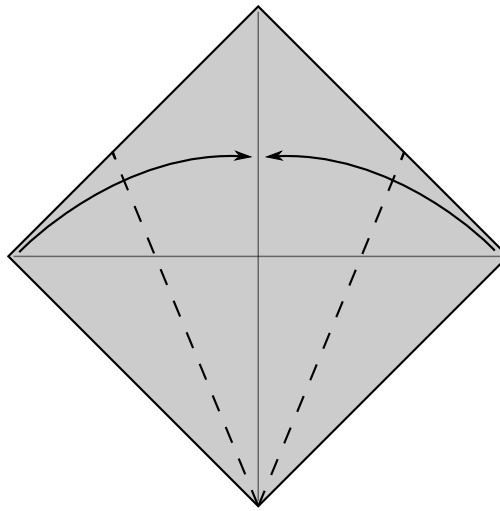

2. Kite fold.

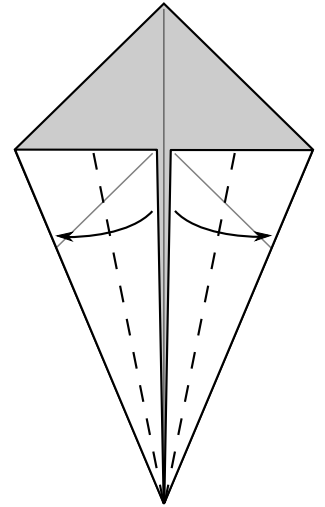

3. Make two valley folds.

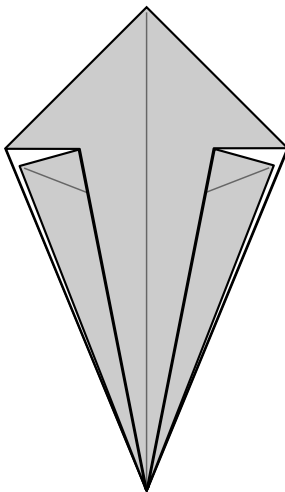

4. Turn over.

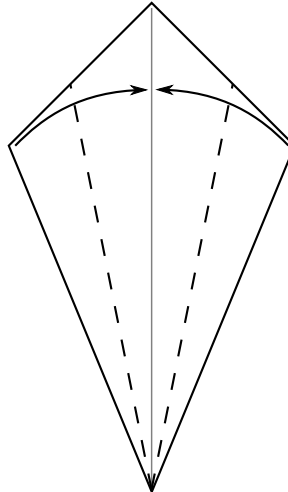
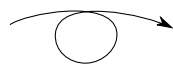

5. Kite fold.

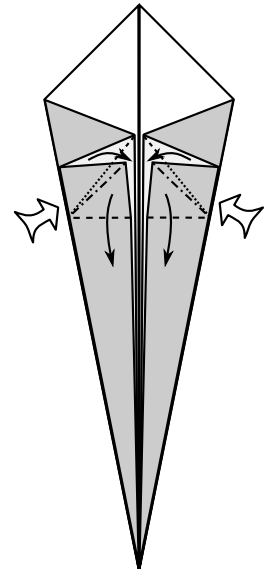

6. Make two squash folds.

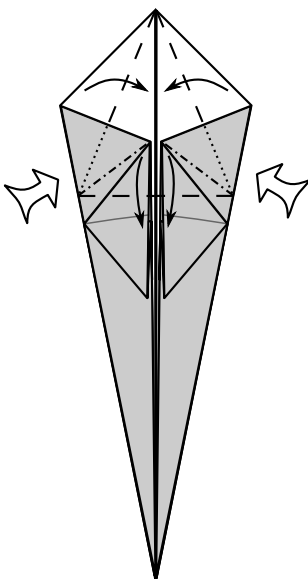

7. Make two squash folds.

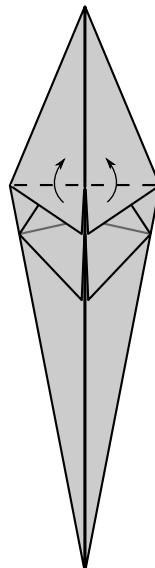

8. Fold two flaps up.

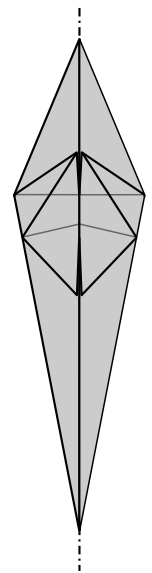

9. Mountain-fold the paper in half from top to bottom.

1/4

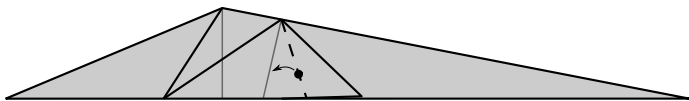

**10.** Fold the indicated point to the crease line. Repeat behind.

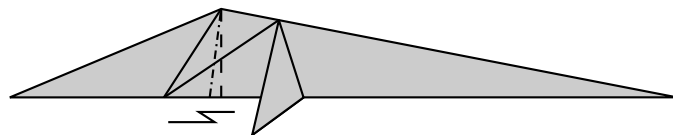

**11.** Make a little crimp fold. Repeat behind.

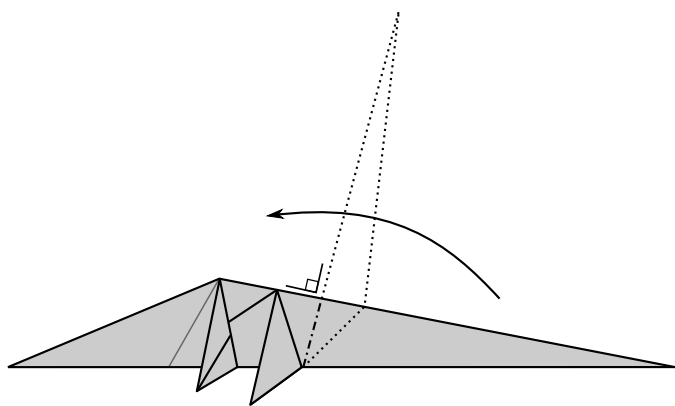

**12.** Inside reverse-fold.

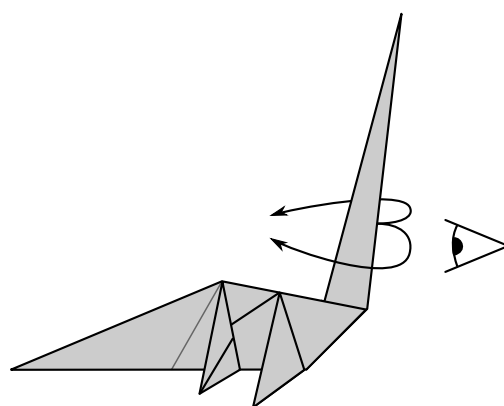

**13.** Open the layers.

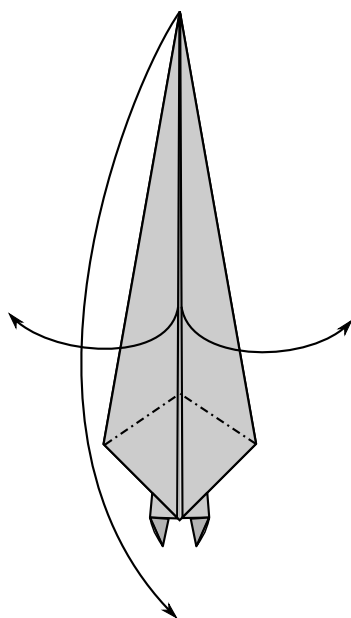

**14.** Front view of 13. Open the layers and fold the flap down.

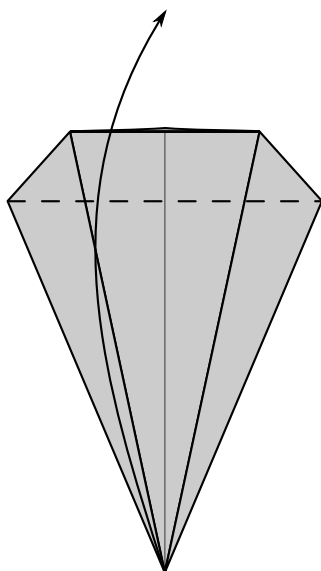

**15.** Fold the flap up.

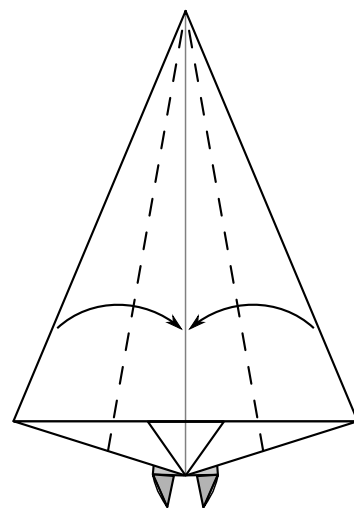

**16.** Valley-fold the sides to the centerline.

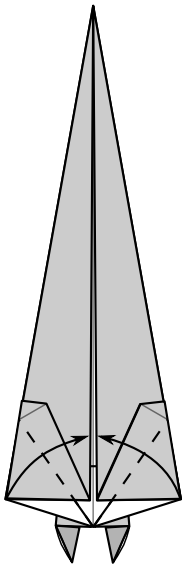

17. Fold the two corners to the middle.

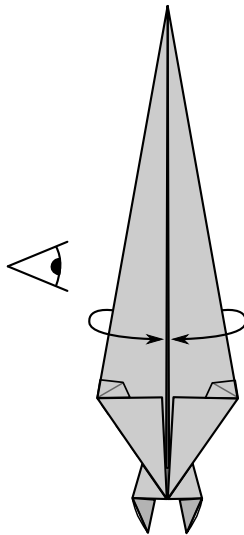

18. Close the layers.

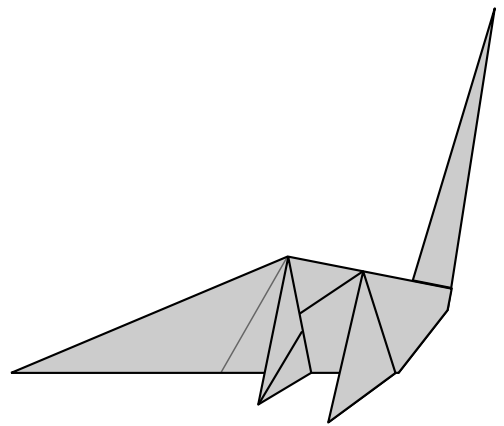

19. Side view of 18.

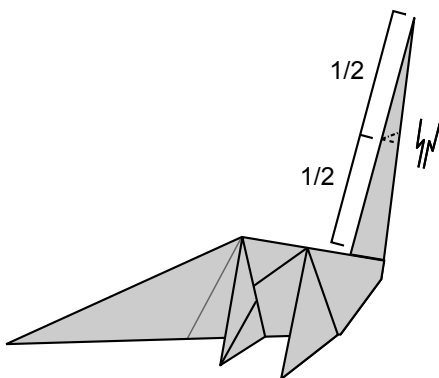

20. Crimp-fold at half-way of the neck.

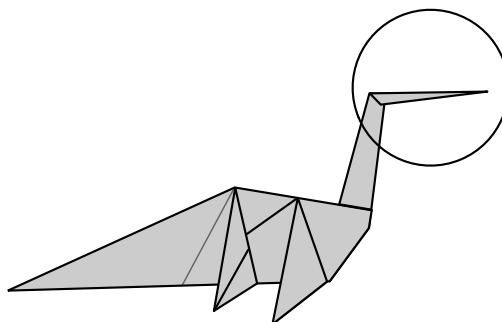

21. Detailed view.

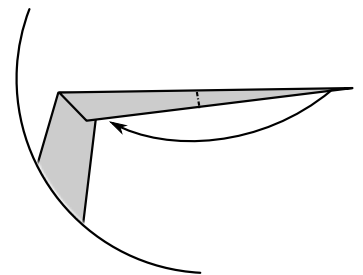

22. Inside reverse-fold.

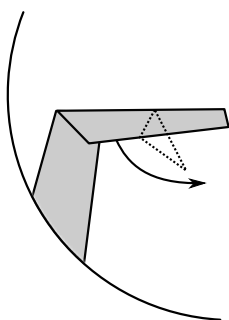

23. Inside reverse-fold to make the muzzle.

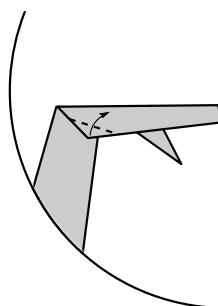

24. Like this. Valley-fold the eye up.

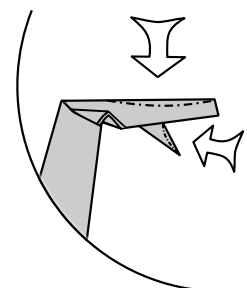

25. Shape the head.

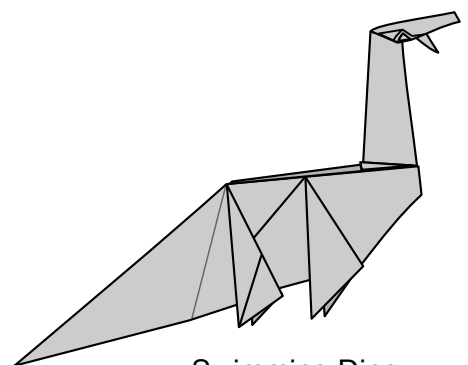

Swimming Dino.